

KWC
 ARMATUREN
 ROBINETTERIE
 RUBINETTERIA
 GRIFERIA
 FAUCETS
802 104

07/04

Montage- und Serviceanleitung**Instructions de montage et d'entretien****Istruzioni di montaggio e di assistenza****Instrucciones de montaje y servicio****Installation and service instructions**

Küchenmischer mit Schwenkauslauf
Mitigeur de cuisine avec bec orientable
Miscelatore da cucina con bocca orientabile
Mezclador de cocina con boca orientable de salida
Kitchen faucet with swivel spout

KWC DOMO
KWC ORCINO
KWC VITA-UNO
KWC VITA-DUO
KWC STAR

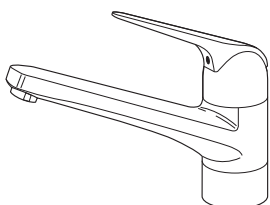

KWC DOMO
K.10.61.23

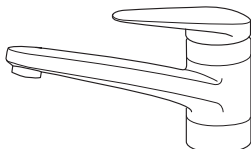

KWC ORCINO
K.10.71.23

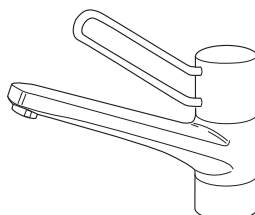

KWC VITA-UNO
K.10.U1.23

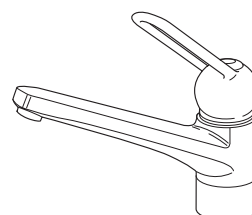

KWC VITA-DUO
K.10.T1.23

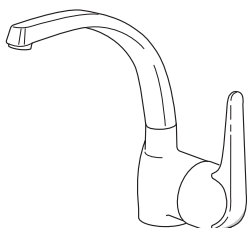

KWC DOMO
K.10.61.12/13

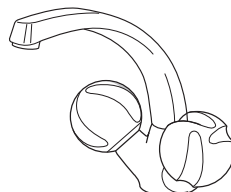

KWC STAR
K.10.41.22/23

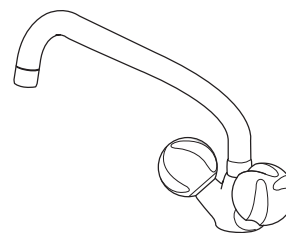

KWC STAR
K.10.41.92/93

D Betriebsdaten:
 Idealer Betriebsdruck : 3 bar
 Max. Betriebsdruck : 5 bar
 Ideale Wassertemperatur : 60 °C
 Max. Wassertemperatur : 90 °C



Vor Montage die Leitungen gründlich durchspülen!

F Caractéristiques de fonctionnement
 Pression de service idéale : 3 bar
 Pression de service max. : 5 bar
 Température idéale de l'eau : 60 °C
 Température max. de l'eau : 90 °C



Rincer à fond la tuyauterie avant le montage!

I Caratteristiche di funzionamento
 Pressione di servizio ideale : 3 bar
 Pressione di servizio mass. : 5 bar
 Temperatura acqua calda ideale : 60 °C
 Temperatura acqua calda mass. : 90 °C



Risciacquare bene le tubazioni prima del montaggio!

Sp Características de funcionamiento
 Presión ideal de servicio : 3 bar
 Presión máxima de servicio : 5 bar
 Temperatura ideal del agua : 60 °C
 Temperatura máxima del agua : 90 °C



Limpiar escrupulosamente las tuberías antes del montaje!

E Operating data
 Ideal operating pressure : 3 bar (45 PSI)
 Max. operating pressure : 5 bar (70 PSI)
 Ideal water temperature : 60 °C (140°F)
 Max. water temperature : 90 °C (190°F)



Before installation flush pipes thoroughly!



Recyclingpapier auf 100% Altpapierbasis.
 Papier de recyclage sur 100% bases de vieux papier.
 Riciclaggio della carta sulla base della carta straccia di 100%.
 Reciclaje del documento sobre base del papel usado del 100%.
 Recycling paper on 100% waste paper basis.

Schweiz, Suisse:
 KWC AG
 Hauptstrasse 57
 CH-5726 Unterkulm

Deutschland:
 KWC Deutschland GmbH
 Rigipsstraße 15
 D-71083 Herrenberg

France:
 Hansa France
 Rue Ettore Bugatti
 F-67038 Strasbourg-Cedex 2

Italia:
 KWC Italia S.r.l.
 Via A.Meucci 54
 I-36057 Arcugnano (VI)

Oesterreich:
 Hansa Austria GmbH
 Rottfeld 7
 A-5020 Salzburg

USA:
 KWC Faucets Inc.
 1770 Corporate Drive #580
 Norcross, Georgia 30093

Tel. : 062 768 67 77
 Fax : 062 768 61 69

Tel. : 07032 7809 0
 Fax : 07032 7809 30

Tel. : 03 88 78 88 08
 Fax : 03 88 76 55 32

Tel. : 0 44 496 48 20
 Fax : 0 44 496 47 35

Tel. : 0662 433 100
 Fax : 0662 433 100 20

Phone: 678 334 2121
 Fax: 678 334 2128

Befestigung

Fixation

Fissaggio

Fijación

Connection

1

Stützenbefestigung
Fixation par tube fileté
Fissaggio con codolo filettato
Fijación de las tubuladuras
Threaded connection mounting

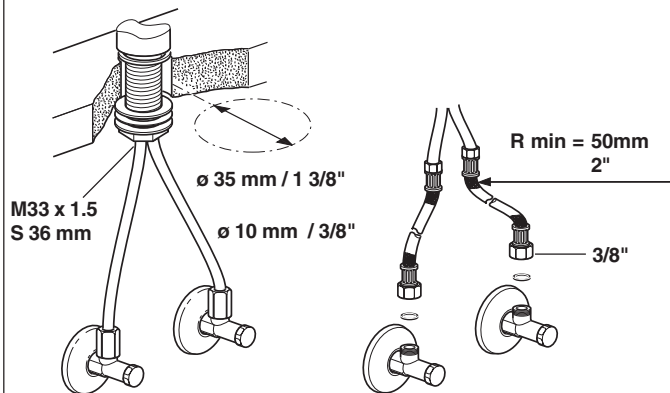
**Z.503.315**

D Für grössere Auflagedicken gibt es Verlängerungsmuttern 40 mm.
 - Bohrung hierfür min. 36 mm

F Pour les épaisseurs supérieures, utiliser l'écrou prolongé 40 mm.
 - Perçage nécessaire au moins 36 mm

I Per spessori superiori ci sono i dadi prolungati 40 mm.
 - Occorre un foro di almeno 36 mm

Sp Para espesores de superficies de apoyo mayores se dispone
 tuercas de prolongación 40 mm.
 - Perforación para tal caso, min. 36 mm

E Available for larger mounting surface thicknesses:
 extension nuts 40 mm / 1 1/2"
 - Bore for extension nut min. 36 mm / 1 1/2"

Stehbolzenbefestigung

Fixation par tige filetée

Fissaggio con asta filettata

Fijación de los espárragos

Stud bolt mounting

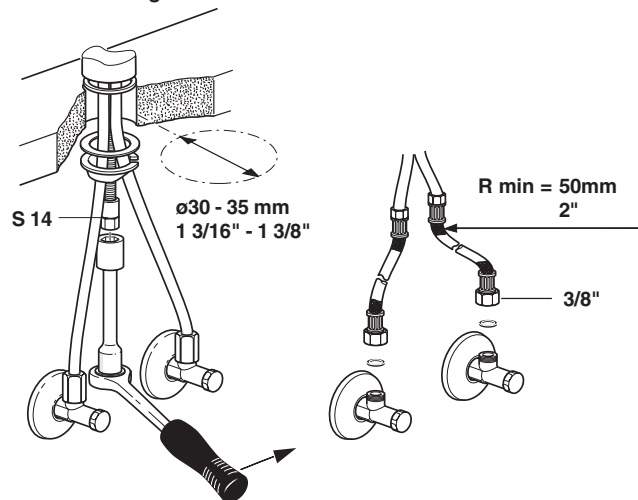
**Inbetriebsetzung**

Mise en service

Messa in funzione

Puesta en servicio

Initial operation

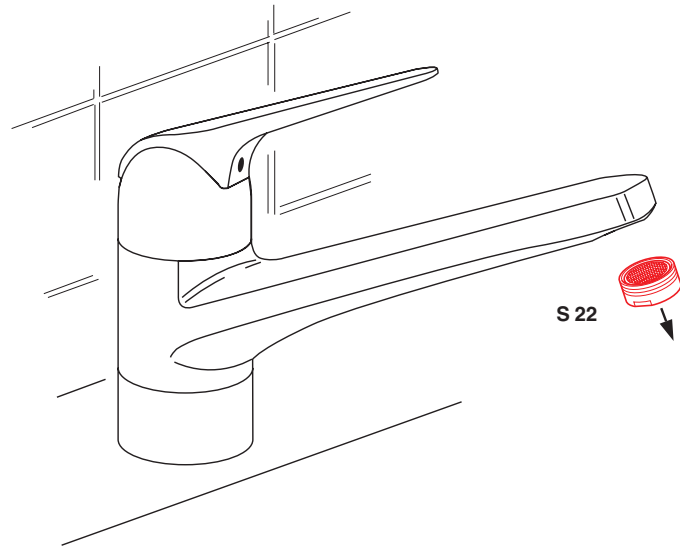
2

D - Eckregulierventile öffnen.
 - Mischer spülen.
 (zuerst Neoperl demontieren).

F - Ouvrir les robinets d'arrêt.
 - Rincer le mitigeur.
 (démonter d'abord le Neoperl).

I - Aprite i rubinetti a gomito.
 - Sciacquate il miscelatore.
 (dopo aver smontato il Neoperl).

Sp - Abrir las válvulas de regulación angular.
 - Enjuagar el mezclador.
 (desmontar primero el aerador).

E - Open corner regulating valves.
 - Flush with cold and hot water.
 (First remove Neoperl aerator).

Mengenbegrenzung
Limitation du débit
Limitazione della portata
Limitación del caudal
Limitation of faucet flow rate

3

Höchsttemperaturbegrenzung
Limitation de la température max.
Limitazione della temperatura massima
Limitación de la temperatura máxima
Maximum temperature limitation

4

KWC ORCINO KWC DOMO KWC VITA-DUO

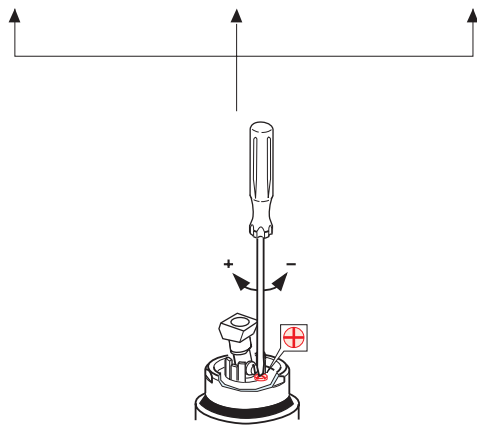
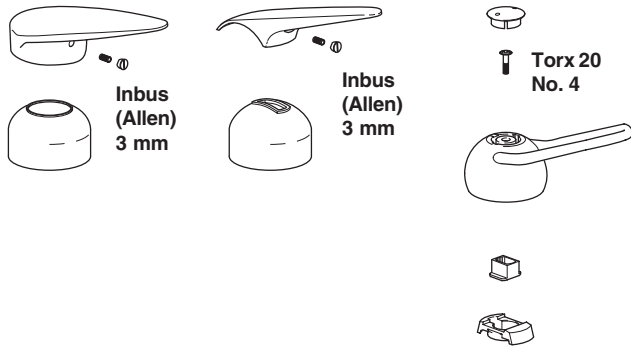

KWC VITA-UNO

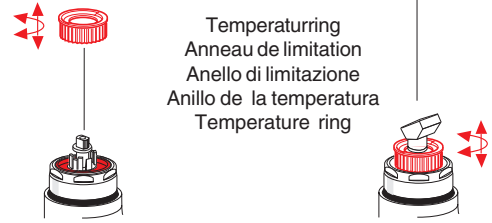
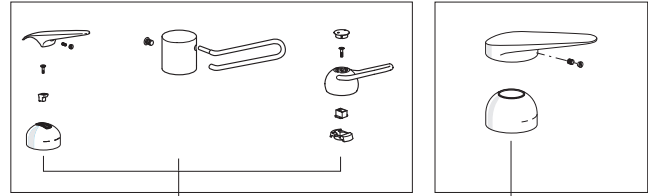
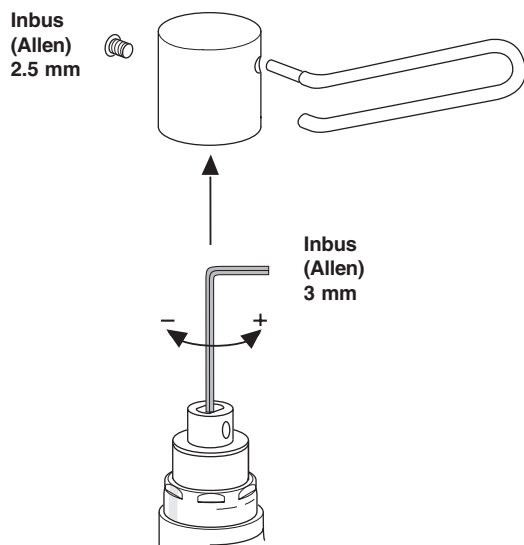

Temperaturring
 Anneau de limitation
 Anello di limitazione
 Anillo de la temperatura
 Temperature ring

Max. Temperaturbereich :
 Plage de température max. :
 Campo di temperatura mass. :
 Gama de temperaturas máx. :
 Max. temperature range :

Begrenzter Temperaturbereich :
 Plage de température réduite :
 Campo di temperatura ridotto :
 Gama de temperaturas reducidas :
 Reduced temperature range :

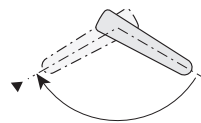
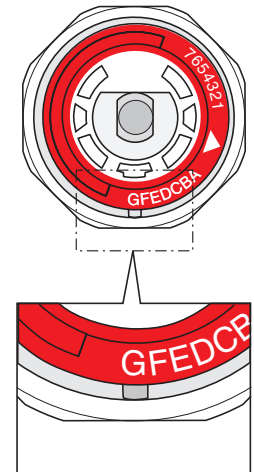
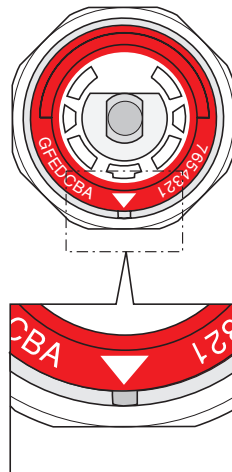

Pfeil auf Kerbe.
 Flèche sur encoche.
 Freccia su scanalatura.
 Flecha en la hendidura.
 Arrow on groove.

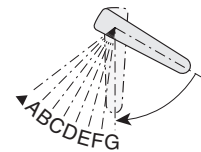

Position A - G.
 Position A - G.
 Position A - G.
 Posición A - G.
 Positions A - G.

Austausch der Steuerpatrone
Remplacement de la cartouche
Sostituzione della cartuccia
Recambio del cartucho de mando
Changing of the control cartridge

5

Ersatzteile
Pièces de rechange
Pezzi di ricambio
Repuestos
Spare parts

6

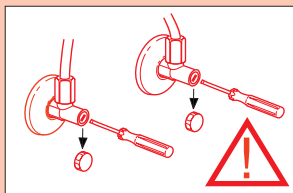

Kalt- und Warmwasser absperren.
Fermer eau froide et chaude.
Chiudere acqua fredda e calda.
Interrumpir la salida de agua fría y caliente.
Turn off cold and hot water.

KWC ORCINO

KWC DOMO

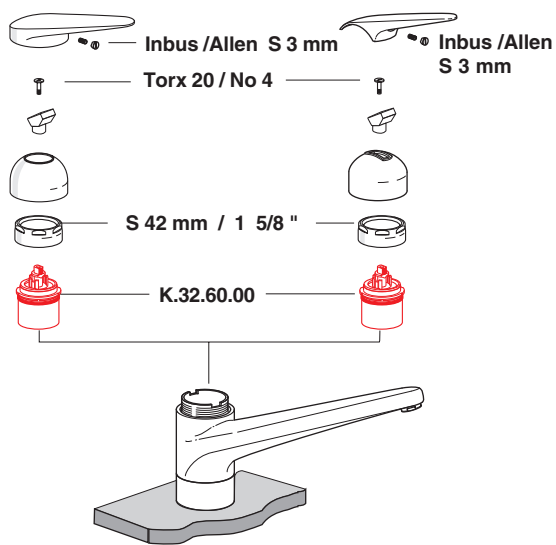

KWC VITA- UNO

KWC VITA- DUO

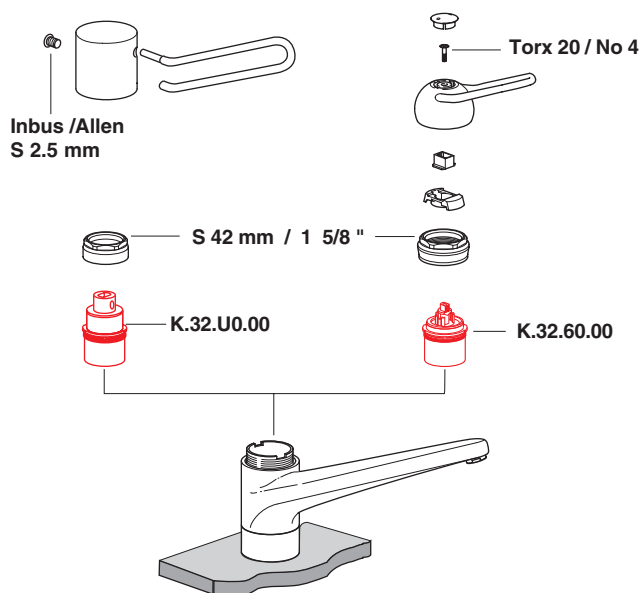

KWC STAR

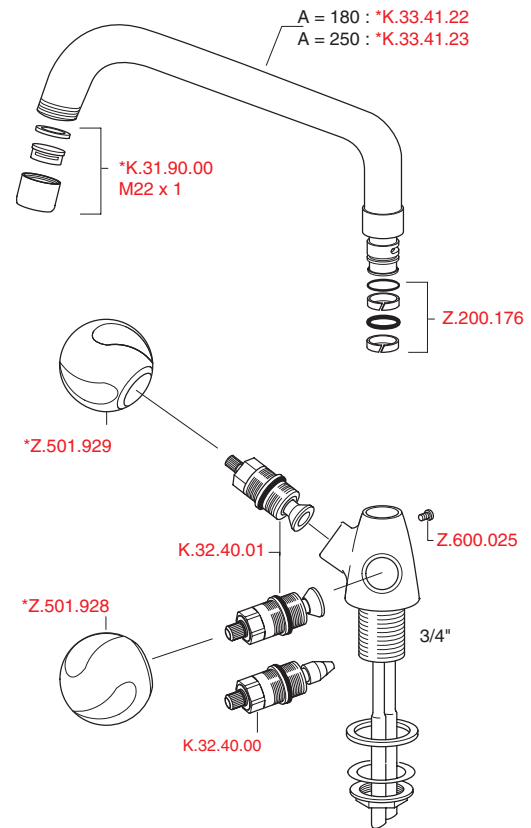

D * Bitte bei Bestellung Farbe angeben.
F * Lors de la commande, veuillez indiquer la couleur, s.v.p.
I * P.f., nell' ordinazione indicare il colore.
Sp * Rogamos indique el color al hacer el pedido.
E * Please specify the color when placing your order.

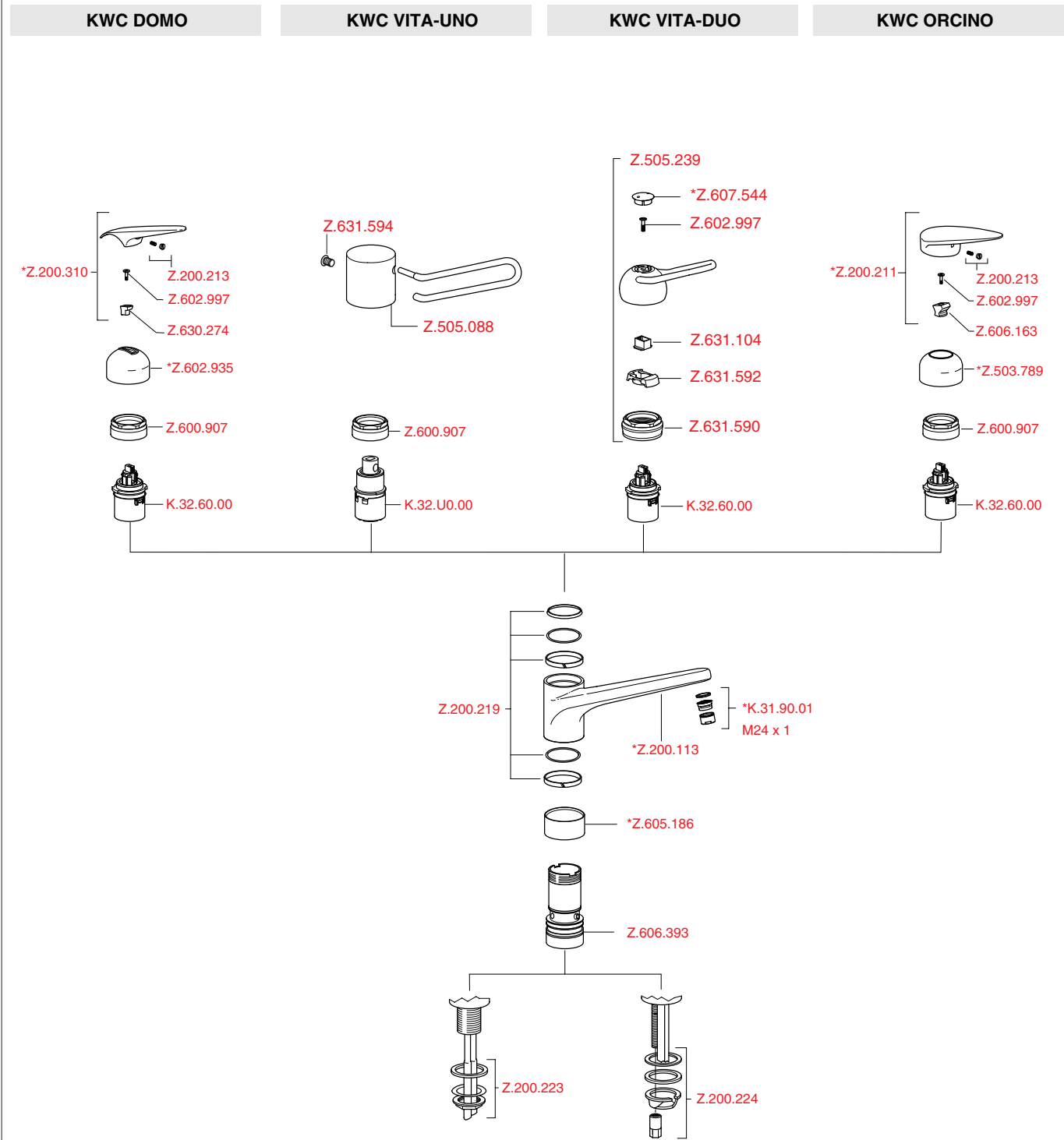

D * Bitte bei Bestellung Farbe angeben.
 F * Lors de la commande, veuillez indiquer la couleur, s.v.p.
 I * P.f., nell' ordinazione indicare il colore.
 Sp * Rogamos indique el color al hacer el pedido.
 E * Please specify the color when placing your order.

KWC STAR

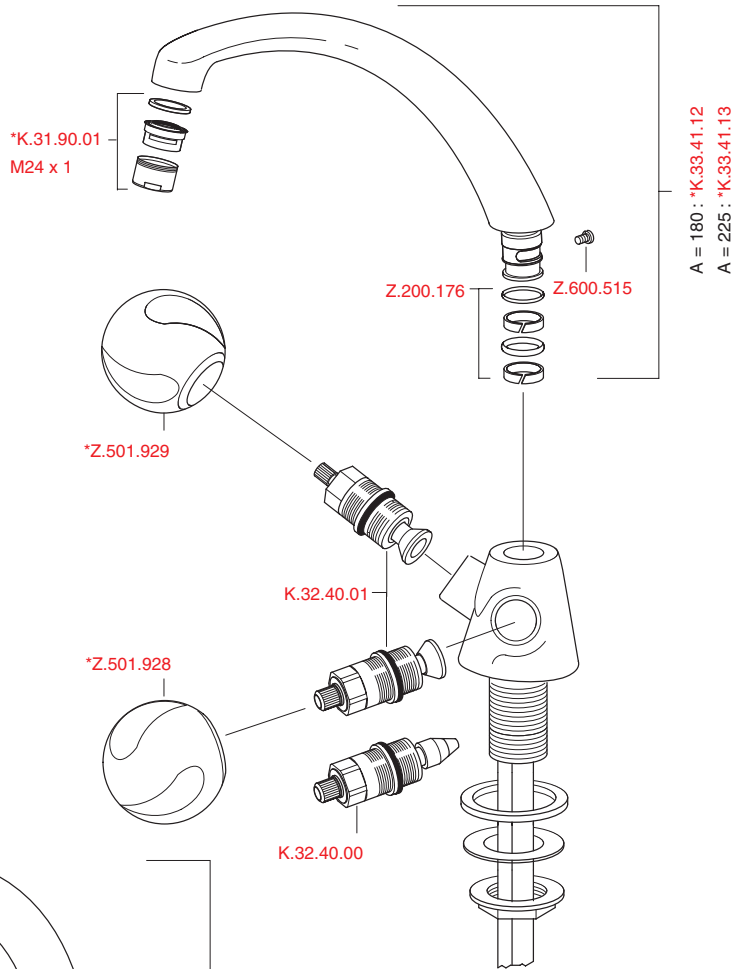

KWC DOMO

