

KWC

ARMATUREN 
ROBINETTERIE
RUBINETTERIA
GRIFERIA
FAUCETS

802 181

01/05

Montage- und Serviceanleitung

Instructions de montage et d'entretien

Istruzioni di montaggio e di assistenza

Instrucciones de montaje y servicio

Installation and service instructions

Einlochmischer und Wandmischer

Mitigeur monotrou et mitigeur mural

Miscelatore monoforo e miscelatore a parete

Mezclador monoblock y mezclador mural

Single hole faucet and wall-mount faucet

KWC DISKO

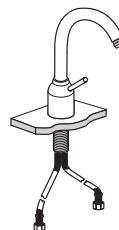
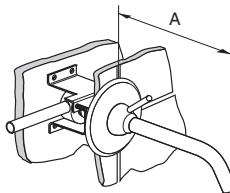
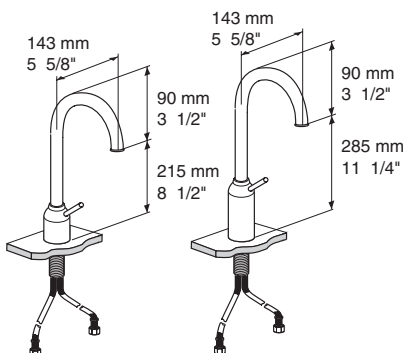

Messing
Laiton
Ottone
Latón
Brass

K.12.VA.42/52

K.12.VA.92

K.11.VA.72 A = 150mm / 6"
K.11.VA.74 A = 230mm / 9"
K.11.VA.76 A = 305mm / 12"

K.13.VA.41

Edelstahl
Acier inoxydable
Acciaio inossidabile
Acero inoxidable
Stainless steel

K.12.VB.42/52

K.12.VB.92

K.11.VB.72 A = 150mm / 6"
K.11.VB.74 A = 230mm / 9"
K.11.VB.76 A = 305mm / 12"

K.13.VB.41

Schweiz, Suisse:

KWC AG
Hauptstrasse
CH-5726 Unterkulm

Tel. : 062 768 67 77
Fax : 062 768 61 69

Italia:

KWC Italia SRL
Via A. Meucci, 54
36057 Arcugnano (VI)

Tel. : 444 96 48 20
Fax : 444 96 47 35

Deutschland:

KWC Deutschland GmbH
Rigipsstraße 15
71083 Herrenberg 6

Tel. : 07032-7809 0
Fax : 07032-7809 30

USA:

KWC Faucets Inc.
1770 Corporate Drive # 580
Norcross, GA 30093

Phone : 678 334 2121
Fax : 678 334 2128

Oesterreich:

KWC Armaturen GmbH
Rotfeld 7
5020 Salzburg

Tel. : 0662 433 100 0
Fax : 0662 433 100 20

France:

KWC Robinetterie S.a.r.l.
Quartier d'Entreprises
Rue Ettoré Bugatti
67200 Eckbolsheim
Tel. : 0388 49 41 00
Fax : 0388 49 41 05



Recyclingpapier auf 100% Altpapierbasis.
Papier de recyclage sur 100% bases de vieux papier.
Riciclaggio della carta sulla base della carta straccia di 100%.
Reciclaje del documento sobre base del papel usado del 100%.
Recycling paper on 100% waste paper basis.

Betriebsdaten**Caractéristiques de fonctionnement****Caratteristiche di funzionamento****Datos de servicio****Operating data****Betriebsdaten:**

Idealer Betriebsdruck	: 3 bar
Max. Betriebsdruck	: 5 bar
Druckgleichheit empfehlenswert.	
Ideale Wassertemperatur	: 60 °C
Max. Wassertemperatur	: 80 °C

Caractéristiques de fonctionnement

Pression de service idéale	: 3 bar
Pression de service max.	: 5 bar
Egalité de pression recommandée.	
Température idéale de l'eau	: 60°C
Température max. de l'eau	: 80°C

**Achtung:**

Vor Montage die Leitungen gründlich durchspülen!

**Attention:**

Rincer à fond la tuyauterie avant le montage!

Weitere Informationen finden Sie in unseren detaillierten Verkaufsunterlagen.

Pour informations supplémentaires voir nos documentations de vente détaillées.

Caratteristiche di funzionamento

Pressione di servizio ideale	: 3bar
Pressione di servizio mass.	: 5bar
Si raccomanda pressioni uguali.	
Temperatura acqua calda ideale	: 60°C
Temperatura acqua calda mass.	: 80 °C

Datos de servicio

Presión ideal de servicio	: 3 bar
Presión máxima de servicio	: 5 bar
Se recomienda la igualdad de las presiones.	
Temperatura ideal del agua	: 60 °C
Temperatura máxima del agua	: 80 °C

**Attenzione:**

Risciacquare bene le tubazioni prima del montaggio!

**Atención:**

Enjuagar escrupulosamente las tuberías antes del montaje!

Ulteriori informazioni le troverete nelle nostre dettagliate documentazioni.

Información más detallada en nuestra documentación de ventas.

Operating data

Ideal operating pressure	: 3 bar (45 PSI)
Max. operating pressure	: 5 bar (70 PSI)
Equal pressures are recommended.	
Ideal water temperature	: 60 °C (140°F)
Max. water temperature	: 80 °C (180°F)

**Attention:**

Before installation flush pipes thoroughly!

For further information refer to our detailed sales literature.



- D** Schäden, die infolge unsachgemässer Behandlung, natürlicher Abnutzung oder zu grosser Inanspruchnahme entstanden sind, sind von unseren Garantieleistungen ausgeschlossen!
- F** Ces dommages survenus en raison d'un traitement inadéquat, des signes d'usure traitement inadéquat, naturels ou du grand utilisation, sont exclus de notre garantie.
- I** Danni ai rubinetti, conseguenti da un trattamento non appropriato, sono esclusi dalla nostra garanzia!
- Sp** Daños, debidos a un tratamiento inadecuado, son excluidos de la nuestra garantía.
- E** Damages of the faucets as a result of incorrect handling are excluded from the manufacturers warranty!

Befestigung

Fixation

Fissaggio

Fijación

Connection

Max. 30mm
Max. 1 3/16"

ø 35mm
ø 1 3/8"

R min = 50mm / 2"

3/8"
(USA: 9/16")

K.12.VA.42/52/92

K.12.VB.42/52/92

K.13.VA.41/51

K.13.VB.41/51

Z.503.315 Verlängerung
Ecrou allongé
Dadi prolungati
Tuerca de prolongación
Extension nut

K.11.VA.72 / 74 / 76

K.11.VB.72 / 74 / 76

1

47 mm
1 27/32"

95 mm
3 3/4"

2

warm
chaud
caldo
caliente
warm

G 1/2"

3

min: 71 mm / 2 25/32"
ideal + max: 106 mm / 4 3/16"

ø 100 mm
ø 4"

4

5

ø 130 mm

6

Inbus / Allen
S 3mm

Inbus / Allen
S 3mm

D Mischer spülen (zuerst Neoperl demontieren).
F Rincer le mitigeur (demonter d'abord le Neoperl).
I Sciacquare il miscelatore (dopo aver smontato il Neoperl).
Sp Lavar el mezclador (desmontar primero el aerador).
E Flush with cold and hot water (First remove Neoperl aerator).

Höchsttemperaturbegrenzung

Limitation de la température max.

Limitazione della temperatura massima

Limitación de la temperatura máxima

Maximum temperature limitation

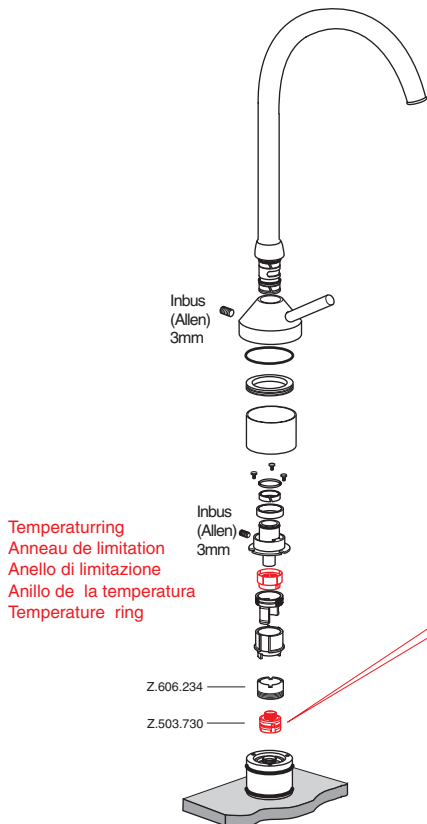

Austausch der Steuerpatrone

Remplacement de la cartouche

Sostituzione della cartuccia

Recambio del cartucho de mando

Replacing of the control cartridge



D Kalt- und Warmwasser absperrn.

F Fermer eau froide et chaude.

I Chiudere acqua fredda e calda.

Sp Interrumpir la salida de agua fría y caliente.

E Turn off cold and hot water.

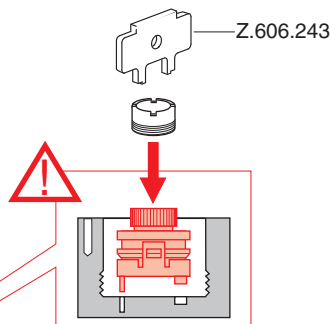

Umbau auf schwenkbar

Changement pour use a bec orientable

Cambio per uso a bocca orientabile

Cambio para uso de bocca orientable

Change on swivel spout

Max. Temperaturbereich :	Begrenzter Temperaturbereich :
Plage de température max. :	Plage de température réduite :
Campo di temperatura mass. :	Campo di temperatura ridotto :
Gama de temperaturas máx. :	Gama de temperaturas reducidas :
Max. temperature range :	Reduced temperature range :

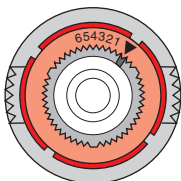

Pfeil auf Kerbe.
Flèche sur encoche.
Freccia su scanalatura.
Flecha en la hendidura.
Arrow on groove.

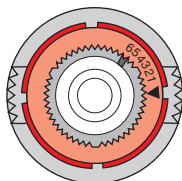

Position 1 - 6
Position 1 - 6
Position 1 - 6
Posición 1 - 6
Positions 1 - 6

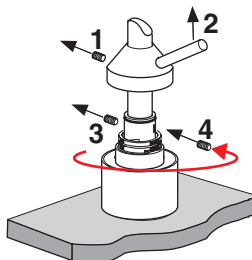

Ersatzteile

Pièces de rechange

Pezzi di ricambio

Repuestos

Spare parts

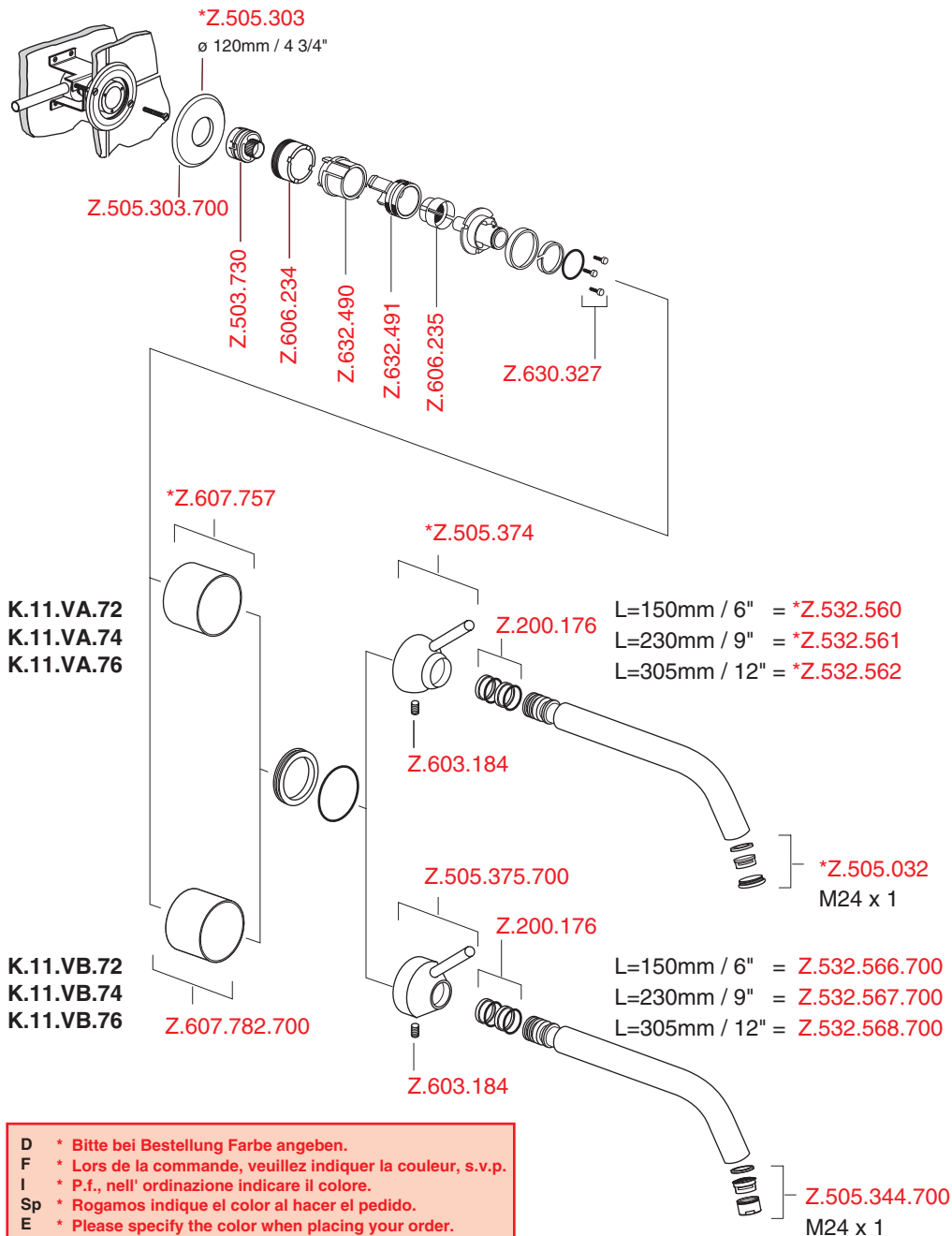

Ersatzteile

Pièces de rechange

Pezzi di ricambio

Repuestos

Spare parts

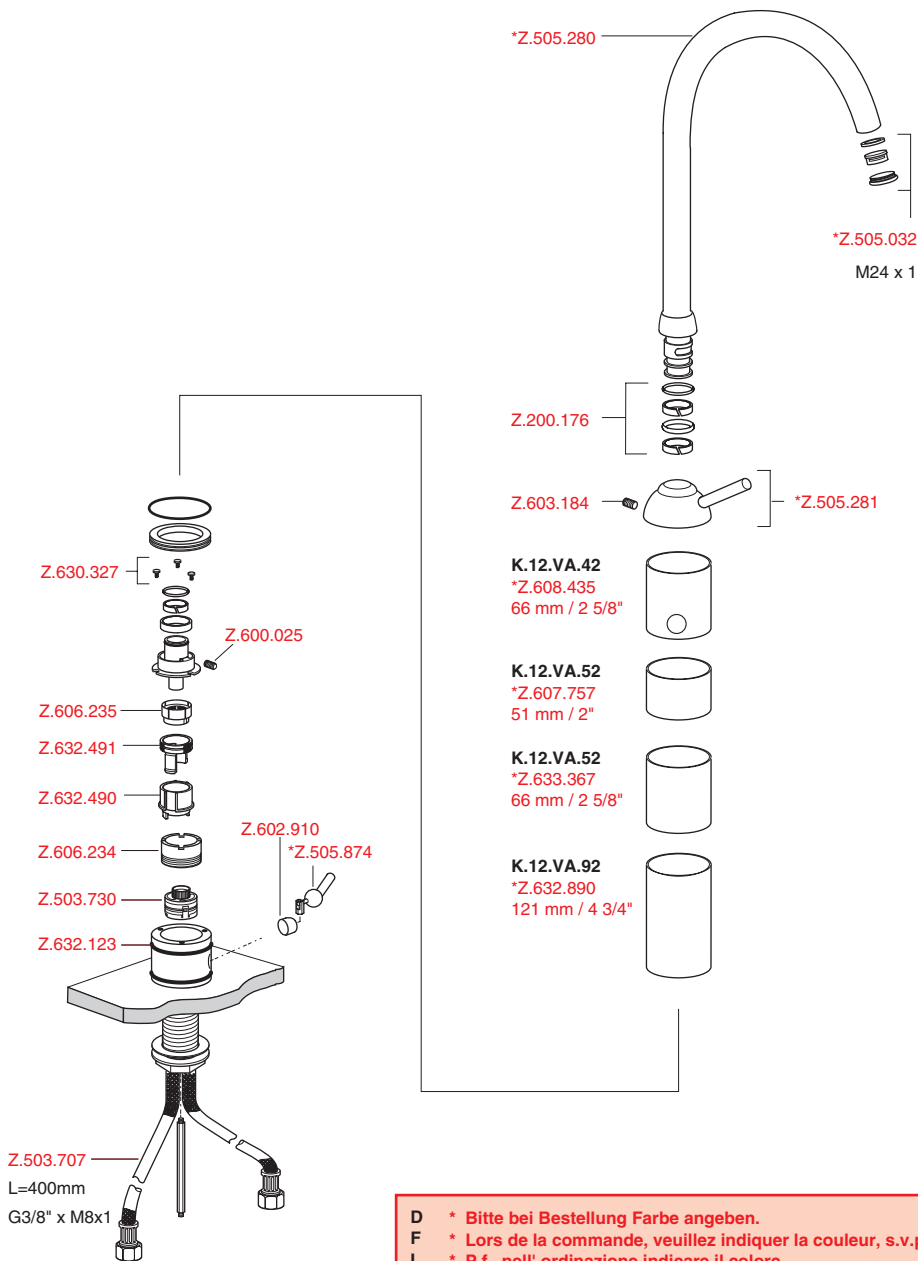

- D** * Bitte bei Bestellung Farbe angeben.
F * Lors de la commande, veuillez indiquer la couleur, s.v.p.
I * P.f., nell' ordinazione indicare il colore.
Sp * Rogamos indique el color al hacer el pedido.
E * Please specify the color when placing your order.

Ersatzteile

Pièces de rechange

Pezzi di ricambio

Repuestos

Spare parts

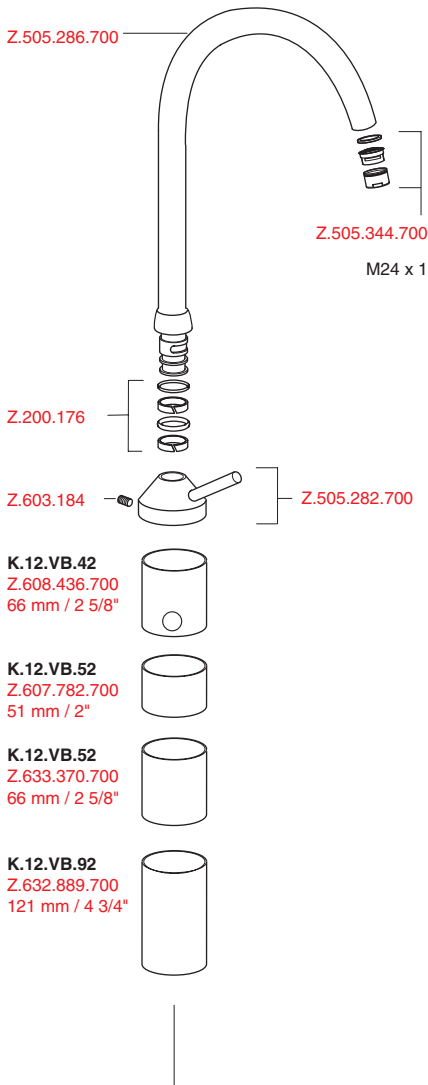
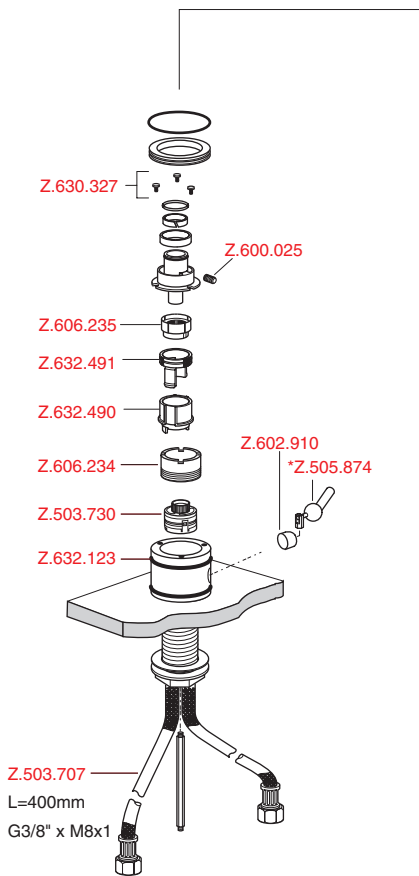

Ersatzteile

Pièces de rechange

Pezzi di ricambio

Repuestos

Spare parts

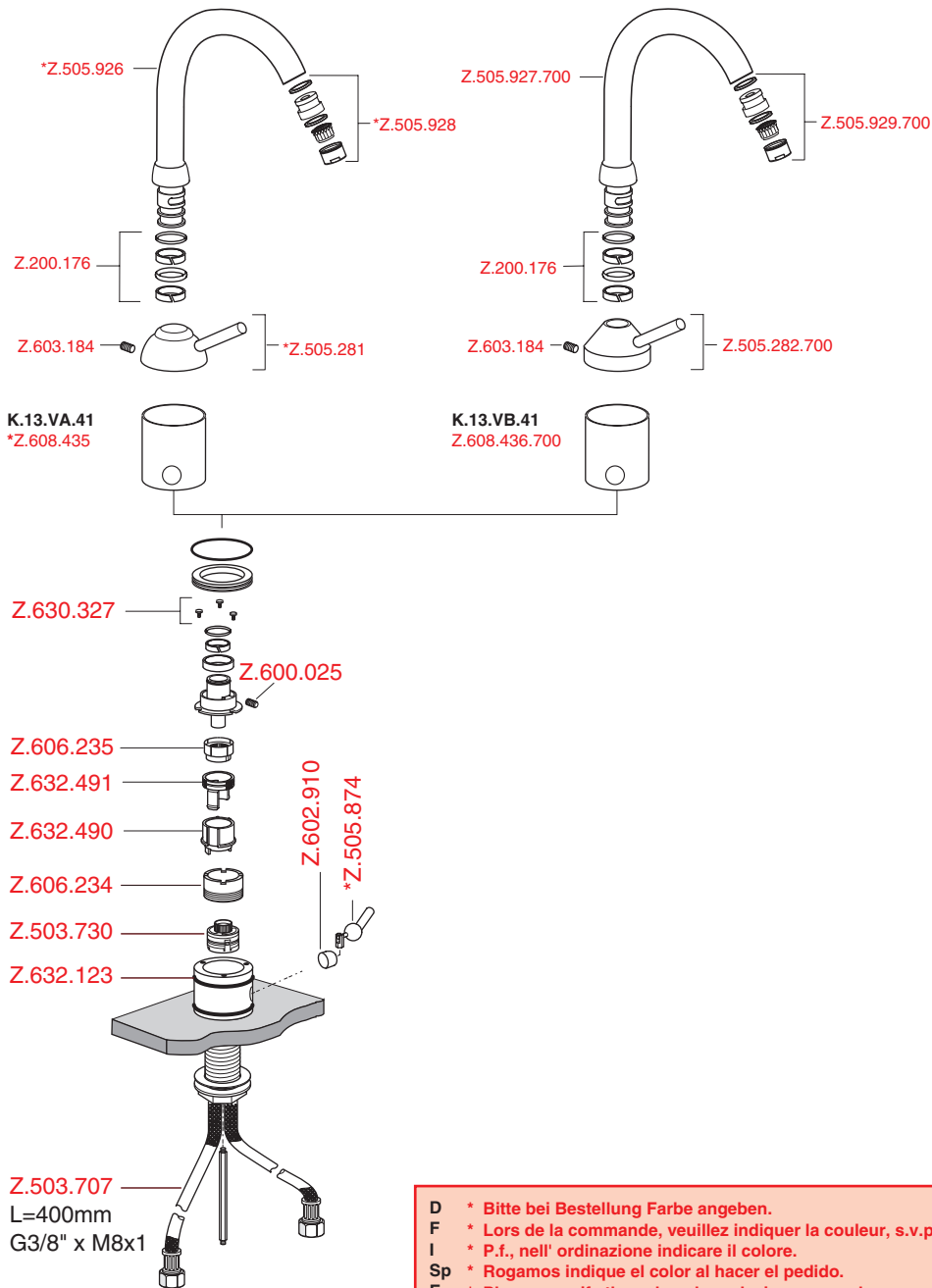

D * Bitte bei Bestellung Farbe angeben.
 F * Lors de la commande, veuillez indiquer la couleur, s.v.p.
 I * P.f., nell' ordinazione indicare il colore.
 Sp * Rogamos indique el color al hacer el pedido.
 E * Please specify the color when placing your order.